

UNITED STATES STRENGTHLIFTING FEDERATION



STRENGTHLIFTING TECHNICAL RULES

Updated: 01/17/2023

TECHNICAL RULES INDEX

1.	<i>GENERAL RULES OF STRENGTHLIFTING</i>	3
	a. The Competition Lifts	
	b. Determining Winners	
	c. Divisions	
	d. Weight Classes	
	e. Membership Requirements	
2.	<i>THE STRENGTHLIFTS AND THE RULES OF PERFORMANCE</i>	4
	a. The Press	
	b. The Deadlift	
3.	<i>LIFTING COSTUME AND PERSONAL EQUIPMENT</i>	7
	a. Required Costume: Singlet, Undershirt, Socks, Shoes	
	b. Headwear	
	c. Hair Management	
	d. Belt	
	e. Knee Sleeves	
	f. Wrist Wraps	
	g. Elbow Sleeves	
	h. Ammonia	
	i. Lubricants	
	j. Bandages	
4.	<i>PLATFORM AND EQUIPMENT</i>	8
	a. Platform	
	b. Bar, Discs, and Collars	
	c. Rack	
	d. Judging Lights	
	e. Warmup Facilities	
5.	<i>ORDER OF COMPETITION</i>	9
	a. Registration	
	b. The Rounds System and Flight Requirements	
	c. Attempt Selection	
	d. Misloads	
	e. Music	
	f. Behavioral Conduct	
	g. Weigh-Outs	
	h. Awards	
	i. Officials	
6.	<i>OFFICIAL DOCUMENTS</i>	13
	a. Start List	
	b. Expediter Cards	
	c. Scoresheet	
	d. Waivers	
7.	<i>EVENT DIRECTOR REPORTING REQUIREMENTS</i>	14
8.	<i>APPENDIX</i>	15
	a. Wilks Formula	
	b. Fosters Age Coefficient	
	c. McCulloch Age Coefficient	

GENERAL RULES OF STRENGTHLIFTING

1. The United States Strengthlifting Federation recognizes the following lifts for competition to be completed in this order:
 - a. Press
 - b. Deadlift
2. Competition takes place between lifters in categories as defined by sex, bodyweight and age.
3. Each competitor is allowed three attempts for each lift. The summation of a competitor's best valid attempt for each lift constitutes their Total.
4. The winner of each division shall be the lifter with the highest Total. If two or more lifters achieve the same Total, the lighter of the two lifters will be declared the winner. If the lifters achieve the same total and register the same bodyweight upon weigh-out, the lifter that made the total first will be declared the winner.
5. Best Lifter Awards will be given to the lifter with the best performance based upon the Wilk's formula. If a best Masters Award is to be given it will additionally be based upon the McCulloch formula. If a Best Juniors Award is to be given it will additionally be based upon the Foster coefficient.
6. Divisions:
 - a. Open: Any lifter may opt to compete in the open division
 - b. Women: Congenital females
7. Age classes:
 - a. Adult: 20-39 years old
 - i. Any lifter may opt to lift in the adult division in addition to or instead of their other age class.
 - b. Master: Lifters who turn 40 years or older during the calendar year in which the event is held
 - c. Juniors: Lifters who turn between the ages of 14 and 19 years old during the calendar year in which the event is held. Lifters under the age of 14 may guest lift in a USSF sanctioned event, with a parent or guardian signed waiver form, and pre-approval from the Event Director.
8. Weight classes:
 - a. Open
 - b. Open
 - i. Lightweight I: up to 150.0 lbs
 - ii. Lightweight II: 150.01 up to 175.0 lbs
 - iii. Middleweight I: 175.01 up to 200.0 lbs
 - iv. Middleweight II: 200.01 up to 231.0 lbs
 - v. Heavyweight I: 225.01 up to 250.0 lbs
 - vi. Heavyweight II: 250.01 lbs up to unlimited.

- c. Women
 - i. Lightweight I: up to 120.0 lbs
 - ii. Lightweight II: 120.01 up to 140.0 lbs
 - iii. Middleweight I: 140.01 up to 160.0 lbs
 - iv. Middleweight II: 160.01 up to 180.0 lbs
 - v. Heavyweight I: 180.01 up to 200.0 lbs
 - vi. Heavyweight II: 200 lbs up to unlimited
- 9. USSF Membership must be maintained by all lifters. All lifters must show proper identification (driver's license, passport, school ID) and provide their USSF membership number prior to the commencement of the event. USSF memberships can be obtained here: <https://usstrengthlifting.com/register/ussf-membership/> and are valid for life.

THE STRENGTHLIFTS AND THE RULES OF PERFORMANCE

THE PRESS

1. The press is performed from the rack facing the Head Judge.
2. No spotters will be present on the platform.
3. The bar must be removed from the racks and a position assumed on the platform at least 2' from the racks, or a distance sufficiently removed from the racks to ensure the safety of the lifter in the event of a miss. The removal of the bar, for purposes of timekeeping, indicate the start of the attempt.
4. The bar is held in both hands in front of the neck and taken out of the rack with a prone power grip. The bar sits in the palm with the four fingers wrapped around the bar and the thumb opposed.
5. The starting position must be upright, with the knees and hips fully extended, and the chest up. The bar must start **motionless** below the level of the chin.
6. After the starting position is correctly and obviously assumed, the bar is pressed overhead in one continuous upward motion to a position with elbows completely extended and with the bar behind a vertical line from the most anterior aspect of the armpit to the floor. Any deliberate effort to press the bar after the bar is removed from the racks counts as the attempt. Any athlete who is anatomically unable to fully extend one or both elbows must report the condition to the Judges before the start of every press.
7. Once the overhead position has been obviously assumed and the bar has become motionless, the bar is lowered back down before being walked back into the rack and replaced securely without assistance.

CAUSES FOR DISQUALIFICATION OF THE PRESS

8. Failure to assume a start position with the bar motionless below the chin.
9. After the upward initiation of the press, any downward motion of the center of the bar that occurs prior to lockout, as measured between the hands.

10. Any **bending** of the knees (a “push press”) disqualifies the attempt. Incidental **unlocking** of the knees that clearly does not contribute to upward motion is not a reason to disqualify an attempt.
11. Any active plantar flexion of the ankles.
12. Any pronounced uneven lockout of the elbows.
13. Any deliberate contact or any unintentional contact with the rack that would aid a lifter.
14. Any forward, backward or lateral step during the press itself.
15. Downward motion of the bar occurring from the start position but before upward motion, is permitted and is not a reason to disqualify an attempt.

THE DEADLIFT

1. The bar shall be loaded on the platform in a position parallel to the front of the platform, with the lifter facing the Head Judge. The platform shall be free of any unnecessary equipment, including deadlift jacks.
2. A single spotter will be present for each attempt. The designated spotter will remain off the platform at the ready in case of a syncopal event or other event that requires the rendering of aid.
3. The lifter assumes a position facing the bar, with the vertical plane of the legs parallel to the bar. The bar is gripped with both hands **outside** the legs.
4. If an athlete is missing two or more fingers on a single hand, they may utilize a lifting strap on that hand only.
5. For timekeeping purposes, the attempt begins when the bar leaves the floor.
6. The bar is pulled in a continuous upward motion until the lifter is standing erect with knees and hips fully extended, the chest up, and the shoulders back. Any bona fide attempt to move the bar counts as the attempt.
7. Once the lockout position is attained and the bar is motionless, the bar is lowered under control with both hands back to the ground.

CAUSES FOR DISQUALIFICATION OF THE DEADLIFT

8. Failure to attain a position standing erect with knees and hips fully extended, the chest up, and the shoulders back.
9. Any downward motion of the center of the bar, as measured between the hands, before lockout.
10. Any release of the bar from the hands before it is lowered to the floor.
11. Any forward, backward or lateral step during the deadlift itself.
12. Supporting of the bar on the thighs.
13. Use of any lubricants on the thigh or legs.

THE SQUAT (OPTIONAL – DOES NOT COUNT TOWARDS TOTAL)

1. ~~The squat is performed from a rack facing the Head Judge.~~
2. ~~No less than two and no more than four spotters will be present for each attempt, positioned to have immediate access to each end of the bar. No spotter is permitted to stand directly behind the lifter.~~
3. ~~The bar must be held across the back with some part of both palms in contact with the bar. The bar must not be more than 3cm below the posterior deltoid. The lifter must not hold the collars, sleeves, or weight discs during the lift. Contact of the hands on the inside of sleeves during the lift is permitted. This position, once fixed, cannot change during the attempt.~~
4. ~~The bar must be removed from the racks and a position assumed on the platform at least 2' from the racks, or a distance sufficiently removed from the racks to ensure the safety of the lifter and the spotters in the event of a miss. The removal of the bar, for purposes of timekeeping, indicates the start of the attempt.~~
5. ~~The starting position must be upright, with the knees and the hips fully extended, and with the chest up. This position must be obvious and under control before the descent begins.~~
6. ~~The hips are lowered until the top surfaces of the legs at the hip joint is lower than the knees. The bottom position is identified by (1) the apex of the crease in the singlet formed as the hips are lowered, (2) the surface of the top of the patella, (3) the plane formed by a straight line between the two, and (4) the dipping of the hip end of that plane below horizontal.~~
7. ~~The lifter must then return to the start position in one continuous upward motion. The lifter must once again demonstrate control of this position.~~
8. ~~The lifter must then return the bar to the rack without the assistance of the spotters. Once the bar crosses the threshold of the hooks, spotters may assist in guiding the bar safely down into the hooks.~~

CAUSES FOR DISQUALIFICATION OF THE SQUAT

9. ~~Any change of position of the bar across the shoulders after the start of the lift.~~
10. ~~Any deliberate contact or any unintentional contact with the rack that would aid a lifter.~~
11. ~~Failure to achieve a position of the hips lower than the knees.~~
12. ~~Any downward motion of the center of the bar, as measured between the hands, after upward motion has begun.~~
13. ~~Any supporting of the body with the arms or elbows against the thighs.~~
14. ~~Any direct contact of the bar by the spotters, whether necessary or unintentional, at any point after the lifter unracks the bar but before the lifter crosses the threshold of the hooks.~~
15. ~~Any forward, backward, or lateral step during the squat itself.~~

~~Any intentional loss of contact with the bar during the attempt results in a mandatory disqualification from the event. Any unintentional loss of contact with the bar during the attempt may result in disqualification from the event at the discretion of the Event Director for the safety of the athlete and staff.~~

LIFTING COSTUME AND PERSONAL EQUIPMENT

LIFTING COSTUME

1. The lifter's costume must consist of a singlet, collarless undershirt, socks, and shoes. The items must be clean, free of graphics of a nature that the average spectator would find offensive, fit snugly enough to facilitate judging, but must absolutely not be supportive in any way.
2. The singlet shall be one-piece of single ply stretch material that is non-supportive. An additional layer of material up to 12cm x 24cm is allowed in the area of the crotch.
3. The undershirt can be with or without sleeves. It can be made of cotton, polyester, or a blend. It must not have any pockets, buttons, zippers, or reinforced collars or seams.
4. Socks can be made with any commercially available material. Only one pair of socks can be worn at a time. Socks must be of a length that they do not come into contact with the knee or with knee sleeves. During the deadlift a pair of socks must be worn that covers the top of the calf, ending just below the knee.
5. Shoes of any type may be worn. Shoes must be worn on the platform at all times. Cleats or metal spikes are not permitted.
6. Underwear of any type may be worn provided it is not supportive in any way.
7. A unitard may be worn underneath the costume as long as it meets the following requirements: one or two piece (full body), tight fitting, collarless, and of any single color. Patterns are not permitted.
8. Headwear that is non-obstructive, does not impede the path of the barbell, of a single color, and without graphics may be worn.
9. No headphones or earbuds of any sort are permitted to be worn on the platform.
10. Long hair or beards that interfere with determining the bar's placement with respect to the chin at the start of the press shall be restrained or tied back.
11. All garments are subject to review and approval by the Judges. The use of illegal supportive garments may result in disqualification from the event either currently or retroactively.

PERSONAL EQUIPMENT

12. A belt may be worn during all lifts. It may be of any type, provided that it does not exceed four inches in width at any point along its length. The belt must be worn on the outside of the lifting costume.
13. Rubberized knee sleeves not exceeding 30cm in length or 7mm in thickness may be worn. Only one knee sleeve per knee may be worn. The knee sleeve must be non-adjustable and non-fastening. There can be no visible contact between the socks and the knee sleeves or between the singlet and the knee sleeves. Knee sleeves that fit so tightly that they cannot be easily removed solely by the lifter are prohibited. Officials may at any time ask the lifter to pull their knee sleeves down below the knee and back up again. If this cannot be done without help, the knee sleeves cannot be worn in competition.
14. Wrist wraps of a single ply, not to exceed 1m in length and 8cm in width may be worn.

15. Rubberized elbow sleeves not exceeding 30cm in length and 7mm in thickness may be worn. The elbow sleeve must be non-adjustable and non-fastening. There can be no visible contact between the elbow sleeve and the sleeve of the shirt or the singlet. Elbow sleeves that fit so tightly that they cannot be easily removed solely by the lifter are prohibited. Officials may at any time ask the lifter to pull their elbow sleeve down and back up again. If this cannot be done without help, the elbow sleeve cannot be worn in competition.
16. Thin shin guards that do not impede the upward motion of the bar may be worn under the socks if desired and may be required at the Event Director's discretion.
17. The use of ammonia or smelling salts prior to the lift is permitted so long as their usage takes place off the platform and not within view of the audience.
18. No lubricants of any type, whether fluids, powders, or solids, may be used anywhere on the competition venue or any areas adjacent to the competition venue. Chalk is not considered a lubricant. Use of any lubricants for any purpose constitutes cause for immediate disqualification.
19. The use of counter-irritants is permitted on areas of the skin that do not come in contact with the bar. If there is any uncertainty about whether this use may constitute a use-of-lubricants infraction, the Judges should be consulted prior to their application.
20. No foreign substances of any type except the chalk provided by the competition may be used on either the platform equipment or the lifter's personal equipment. No rosin, spray sticky, or any other substance designed to enhance the friction of hands against bar or shoes against floor may be used.
21. Bandages may be worn for medical necessity with the approval of the Head Judge. Up to two layers of medical tape may be worn around the fingers without the required approval.
22. All personal equipment is subject to review and approval by the Judges. The use of illegal equipment may result in disqualification from the event either currently or retroactively.

PLATFORM AND EQUIPMENT

1. The competition platform shall be a defined area of at least 8' x 8', and shall be surfaced with wood, rubber matting, or commercial non-slip carpeting. It may be a discrete raised structure, or an area of appropriate flooring designated by markings. The entire surface of the platform shall be flat, smooth, level, and flush. If multiple platforms are used in the competition, they shall all be equivalently equipped and staffed. The platform will be kept clear of all unnecessary equipment at all times.
2. The bar shall be high-quality, straight, and well knurled. It shall be 28-29mm in diameter, no greater than 2200mm in length, and have two machined circumferential markings measuring 40.5cm from center.
3. Bars may either be in pounds or kilograms but must match the type of plates being used. The choice between standard or metric measurements must remain consistent between each flight, each lift, and for the entire competition.
4. A bar, weighing less than 45lbs or 20kg, may be used on the press, for any press attempt less than 45lbs or 20kg. This bar must be 25-29mm in diameter, fit securely and safely within the rack, and the sleeves must be standard diameter.

5. The plates shall be of one single style and brand and accurate to a tolerance of +/- 3% of their marked value. The diameter of the largest discs must be 450mm. Plates must be made available to allow for 2.5lb or 1kg increments when loading.
6. When loading the barbell, the heaviest discs are loaded first and facing in. Subsequent discs face outwards.
7. For any deadlift attempt weighing less than 135lbs or 65kg, a 25lb or 10kg bumper of 450mm may be utilized to bring the deadlift bar to a sufficient height.
8. ~~Competition kg collars are required.~~ Collars must be secure and tight when applied.
9. The squat rack shall be of sturdy construction with easily adjustable uprights. Its construction must not impede the spotters from performing their duties safely. A squat rack with swing arms (aka "monolift") is permitted to be used so long as the swing arms remain stationary.
10. Judging lights, paddles, or flags that indicate lift or no-lift must be easily accessible to the Judges and highly visible to the competitors.
11. A chalk box must be provided in close proximity to the platform. It must be supplied with commercially prepared athletic chalk.
12. The warmup facilities must be adequate for the size of the session. It must be equipped comparably to the competition platform, although it need not be identically equipped.
13. The timing clock must be a desktop unit or one projected on a screen, not a stopwatch, visible from a reasonable distance and easily viewed from the platform area. It shall be placed in a conspicuous location adjacent to the Judge acting as timekeeper or on the announcer's table.

ORDER OF COMPETITION

REGISTRATION

1. Registration begins at-least 2 hours before the start of the event and ends 1 hour before. Late registration will not be accepted. Upon check-in, the lifter must provide identification, the intended weight class, press rack height, and opening attempts for each of the lifts. These attempts may be changed later in accordance with the limitations as prescribed in the Conduct of the Competition.

CONDUCT OF THE COMPETITION

2. The event will progress from the press to the deadlift.
3. Lifters will be assigned to specific flights in a manner determined most expedient by the Event Director. When possible, lifters of specific divisions and weight classes will be grouped together.
4. Flights will be posted at a minimum 30-minutes prior to the commencement of lifting.
5. Flights are not to exceed 15 lifters.
6. For any flight less than 10 lifters additional time between rounds will be added. Add 1-minute of rest for 9-lifters, 2 minutes of rest for 8 lifters, and 3 minutes of rest for 7-lifters.

7. Each lifter will take their first attempt in the first round, second attempt in the second round, and third attempt in the third round.
8. The bar will be loaded progressively during each round progressing from the lightest first attempt to the heaviest first attempt.
9. A flight of lifters will complete all three attempts of a particular movement before moving on to the next flight and before moving onto the next movement.
10. Following an attempt, a lifter must immediately leave the platform unless unable to do so because of injury. At the conclusion of the attempt, the lifter has 60 seconds to give their next attempt to the expeditor. In the event of a successful attempt the new weight must be at-least 2.5lbs or 1kg higher. In the event of a missed attempt the new weight may be equal to or greater than the previous attempt but never less. If the next attempt is not received from the lifter or the lifter's coach after a successful lift, it shall be assumed that the next attempt is 2.5lbs or 1 kilogram higher; or, in the case of a previously unsuccessful attempt, the same weight will be repeated.
11. After the opening attempts have been submitted at registration, and for subsequent attempts, 2 changes in the attempt weight can be submitted. Any change in attempt must be submitted before the loading of the attempt is completed and under no circumstances can the weight already loaded on the bar be lowered.
12. In the event of a misload, two things may occur:
 - a. If the misload is discovered before the attempt begins, the clock is stopped, the loading is corrected, and the original allotted time is restored to the clock.
 - b. If the misload is discovered after the attempt, the lifter may elect to take another attempt, or to accept the results of the attempt. If another attempt is granted, it shall be taken at the end of the round during which the error occurred. In the event that a lifter was the last lifter in the round they shall be granted 2 minutes prior to their attempt; second to last lifter shall be granted 1 minute prior to their attempt.
13. Once the bar is loaded and announced as such, the official charged with timekeeping starts the clock, and the lifter has one minute to initiate the attempt. An announcement at the point where thirty seconds remain in the allotted time may be made by the announcer.
14. In the event that two athletes taking the same attempt call for the same weight, the athlete with the lower lot number goes before the athlete with the higher lot number.
15. A failure to complete a successful attempt in any of the two lifts eliminates the athlete from the competition. At the Event Director's discretion, the athlete may be permitted to participate in the next lift.
16. The only persons allowed in the immediate area of the platform and the area of the announcer's table are the Announcer, Expediter, staff, Judges, Loaders, Spotters, the athlete taking the attempt, and the athlete's coach. All other persons must stay clear of this area, upon penalty of removal.
17. If the warm-up facility is not immediately adjacent to the platform area, i.e. if the athletes and coaches in the warm-up facility cannot clearly hear the announcer directly, the public-address system must provide clear information in the warm-up facility.
18. Music may be played over the public-address system, or other loudspeakers, during the competition at a low to moderate level.

19. Any disrespectful, aggressive, or disruptive behavior is grounds for disqualification from the competition and removal from the property at the discretion of the Event Director.

WEIGH-OUT

20. Bodyweight for each lifter will be measured immediately after the last deadlift attempt. An official will be present near the platform to direct lifters to the weigh-out area.
21. Athletes shall present themselves for weigh-out promptly at that time and will have one opportunity to record their weight, after which they shall not be permitted to weigh-out again.
22. Competitors must weigh-out according to their order within their flight. Athletes may be weighed wearing their singlet by an official on an accurate and precise scale. Upon athlete request, a sex-appropriate official can weigh competitors in a private area who wish to remove clothing for the purposes of making weight.
23. Any athlete that weighs out two or more divisions above or below their stated weight class at registration, may be disqualified at the discretion of the Event Director. Disqualifications are given to athletes thought to be intentionally deceptive in order to gain an advantage.
24. Upon completing weigh-outs, the competitor will have successfully completed the event and will be eligible for ranking and awards.

AWARDS

25. The selection of awards are given at the Event Director's discretion.
26. A "Lift of the Night" award may be given. This award is given subjectively to the lift with the most "heart" during the event.
27. A Best Lifter for the Open and Women's division may be awarded, to be calculated from the Wilk's formula.
28. Best Master's lifters may be awarded, calculated based upon Wilk's formula and the McCulloch coefficient.
29. Best Juniors lifter may be awarded, calculated based upon Wilk's formula and the Fosters coefficient.
30. Weight class awards based upon division may be given. Awards are granted to the lifter with the highest total in their class.
31. If a first-place award is shared by two people, there will be no second-place award, only a third. If a second-place award is shared between two people, there will be no third-place award. The third-place award can be shared by two people.

OFFICIALS

32. The Event Director is responsible for carrying out the event in accordance with USSF standards. The Event Director is the final decision maker.
33. Judges
 - a. Three Judges shall serve the competition platform. The Head Judge is seated in front of the lifter, and the two side Judges sit on either side of the lifter at the point of best

vantage. They shall be competent and qualified to serve in this capacity as determined by Event Director.

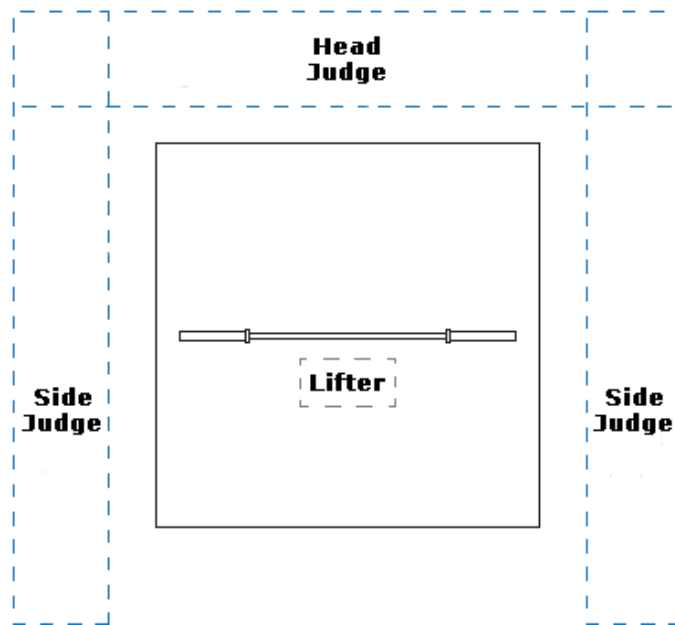

- b. Their duties include but may not necessarily be limited to: ensuring that all the technical rules of competition are followed, that the bar is loaded correctly, and that each attempt is judged with full attention.
- c. When the platform is prepared, and the weight is loaded correctly, the Head Judge will call “platform ready” to indicate to the lifter that their attempt may begin. This duty may be given to the Platform Manager if one is provided.
- d. The Judges indicate their decisions through the use of paddles, flags, or lights. White indicates a good attempt, and red indicates a no-good attempt. Any two Judges in agreement constitute the decision. The athlete or coach may inquire regarding the reason for a Judge’s decision at the discretion of that particular Judge only after leaving the platform area, and only at a time when it does not interfere with the execution of the Judge’s duties.
- e. At any point during the time the lifter is on the platform any Judge sees an infraction of the rules with respect to equipment, conduct, or safety, that Judge can stop the clock and the competition with a raised hand until the situation is rectified to the satisfaction of all the Judges, at which time the clock is restarted.
- f. The Judges must make every effort to render their decisions simultaneously, and to avoid at all costs influencing the decisions of the other Judges through eye contact or discussion with each other between the time the attempt is concluded, and the decision is rendered.
- g. Judges may be replaced at the discretion of the Event Director if it is determined to be in the best interests of the competition.
- h. One of the Judges may act as the timekeeper, or a timekeeper may be appointed to sit with the expediter and announcer, the latter option being preferable.
- i. Judges shall be neatly dressed. Official USSF Judges polo shirts are preferred.

- j. Judges are not permitted to access their cell phones at any point during the performance of their duties.
- 34. The Platform Manager, when provided, ensures the correct and timely loading of the bar and directs the loaders in their duties. Platform Managers are recommended for larger events.
- 35. The Announcer is responsible for the efficient running of the event and for announcing; the progression of the event, the next three lifters about to lift, the name of the current lifter, the weight in kg of the current attempt, and whether the lift was good or no-good. The announcer should abstain from making unofficial commentary about whether a lift was good or no-good before an official decision is rendered.
- 36. The Expediter is responsible for collecting attempts from lifters or their coaches and passing the information on to the score keeper. The expeditor should be provided a clipboard, a series of expeditor cards, a kilo conversion chart, and a lifter flight sheet.
- 37. The Scorekeeper is responsible for accurately recording and displaying the progress of competition. **Lifting Cast is the required scoring software.**
- 38. The Timekeeper is responsible for accurately monitoring the time between announcement of “platform ready” and when the attempt begins.
- 39. Loaders:
 - a. Are responsible for the loading and unloading of the bar, adjusting rack heights, cleaning the bar, and maintaining a safe and tidy platform at all times. Loaders should work quickly and efficiently but most importantly accurately and safely.
 - b. Operate under the direction of the Head Judge or Platform Manager. Ultimately it is the Head Judge’s or Platform Manger’s responsibility to determine the that the bar is correctly loaded.
 - c. Should report any equipment malfunctions, safety issues, or misloads immediately to the Head Judge.
 - d. Should be routinely rotated out to help prevent fatigue related mistakes.
 - e. In the event the bar becomes contaminated with the blood of a competitor, are responsible for disinfecting the bar with 70% isopropyl alcohol, to be applied with a small brush or cloth and allowed to completely dry before the event resumes.
 - f. Are are not permitted to access their cell phones at any point during the performance of their duties.

OFFICIAL DOCUMENTS

The following documents must be established, maintained through the competition, and kept as an official record of the competition:

1. The start list is prepared and published as soon as possible after the entry deadline. It includes the name, lot number, projected weight class, age, division, and session of each entrant in the competition. Lot numbers will be assigned based upon the order in which the event entries were received. An event entry consists of the completed and signed entry form and the entry fee.

2. Expediter cards are assigned to each lifter at check-in. They must include the athlete's name, weight class, division, age, actual weight, and opening attempts for each lift. These are the documents used to run the competition. They should be accessible to coaches and lifters to the greatest extent possible under the constraints of efficient management of the expediter/announcer table.
3. The scoresheet records the results of each lift within the session and is prepared at the end of each lift.
4. Waivers must be signed by any person with access to the platform, warmup area, or any other location not intended as general access for spectators.

EVENT DIRECTOR REPORTING REQUIREMENTS

Following the conclusion of the event, the Event Director is responsible for:

1. Submitting the results of the competition, within 48 hours, exported via Lifting Cast. Results must include the membership ID numbers of every competitor.
2. Providing 5 photos and or videos with captions, taken during the competition to jstanton@usstrengthlifting.com.
3. Providing a photo with captions of the award recipients to jstanton@usstrengthlifting.com.
4. Storing all signed waivers.

APPENDIX

WILKS COEFFICIENT

$$\text{Coef} = (W * 500) / (a + bx + cx^2 + dx^3 + ex^4 + fx^5)$$

W=Weight lifted in kilograms

x=bodyweight of the lifter in kilograms

Values for men are:

$$a = -216.0475144$$

$$b = 16.2606339$$

$$c = -0.002388645$$

$$d = -0.00113732$$

$$e = 7.01863E-06$$

$$f = -1.291E-08$$

Values for women are:

$$a = 594.31747775582$$

$$b = -27.23842536447$$

$$c = 0.82112226871$$

$$d = -0.00930733913$$

$$e = 4.731582E-05$$

$$f = -9.054E-08$$

FOSTER AGE COEFFICIENT

(JUNIORS)	
Age	Coefficient
14	1.23
15	1.18
16	1.13
17	1.08
18	1.06
19	1.04

MCCOLLOCH AGE COEFFICIENT

(MASTERS)					
Age	Coefficient	Age	Coefficient	Age	Coefficient
40	1.000	57	1.268	74	1.795
41	1.010	58	1.291	75	1.835
42	1.020	59	1.315	76	1.876
43	1.031	60	1.340	77	1.918
44	1.043	61	1.366	78	1.961
45	1.055	62	1.393	79	2.005
46	1.068	63	1.421	80	2.050
47	1.082	64	1.450	81	2.096
48	1.097	65	1.480	82	2.143
49	1.113	66	1.511	83	2.190
50	1.130	67	1.543	84	2.238
51	1.147	68	1.576	85	2.287
52	1.165	69	1.610	86	2.337
53	1.184	70	1.645	87	2.388
54	1.204	71	1.681	88	2.440
55	1.225	72	1.718	89	2.494
56	1.246	73	1.756	90	2.549